

# *Density meter for challenging slurry applications*



## **SDM - SLURRY DENSITY METER** **PRODUCT INFORMATION**

## SDM – Non-nuclear Slurry Density Meter

### INTRODUCTION

Rhosonics introduces the Slurry Density Meter (SDM). This robust measuring instrument accurately shows the density value in S.G. (Specific Gravity).

More than ten years of experience with harsh applications has been used for the development of this second generation device. For this reason, the SDM can measure the density of challenging water-based slurries in industries like dredging and mineral processing.

For many years, nuclear devices were the only option. Nowadays the non-nuclear SDM is used to replace these radiation sources. Rhosonics employs the field proven ultrasonic technology for density measurement. The transition to ultrasonic will significantly reduce operational costs, related administration workload and eliminates the associated health and safety risks on-site.

### INDUSTRIES

SDM is used in the following industries:

- Mining and Minerals processing
- Dredging
- Construction
- Energy and power supply
- Any other where density measurement in water-based slurries is required



Mineral slurry



Dredging slurry

### SDM – DESCRIPTION

The Rhosonics Slurry Density Meter has its sensor, analyzer, cable and software integrated in just one system. The density meter is compact and lightweight. In addition, the 'HART' protocol helps to improve communication with the DCS system.



SDM density meter with wafer installation

A single ultrasonic probe is used for accurate density measurements in light to very dense slurries. The density is measured by ultrasonic technology which is non-nuclear and completely environmental friendly.

The sensor is easily mounted and is not intruding the slurry. Furthermore, the sensor is made of durable and abrasion resistant materials for a long service life and low maintenance needs.

### FEATURES AND BENEFITS

- Non-nuclear technology
- Robust, compact and lightweight
- Easy installation and calibration
- Durable probe system
- Lowest possible maintenance needs
- High accuracy and reproducibility
- Suitable for various types of slurries
- Communication via 4 ... 20 mA / HART
- Continuous data logging

- Benefits compared to the nuclear device:
  - no health and safety risks
  - no radiation safety officer (RSO)
  - no licenses or obligatory training
  - no costs for disposal and transport of the radiation source

## RCU – REMOTE CONTROL UNIT

A Remote Control Unit (RCU) is available to read values, convert signals and change settings of the SDM from a convenient location of choice. Please contact Rhosonics for more information.



RCU unit – optional control unit for the SDM

## HOW TO INSTALL

The following guidelines apply for installation:

- Install the sensor with 5xD of straight pipe length upstream or 3xD of straight pipe length downstream.
- The sensors must be installed at a 45° angle position from the bottom of the pipe.

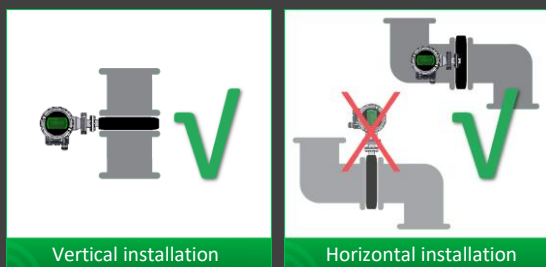

## A TYPICAL APPLICATION

The SDM density meter can be used in many applications to measure the density of a slurry. For the mining industry, typical applications are a thickener underflow and a cyclone feedline. Also applications like dredging, power plant ash, lime stone milk and many others are possible. The measured density value is used for process control but also in combination with flow measurement for production yield.

The Rhosonics SDM ultrasonic density meter is in general THE alternative for nuclear density technology for slurry applications.

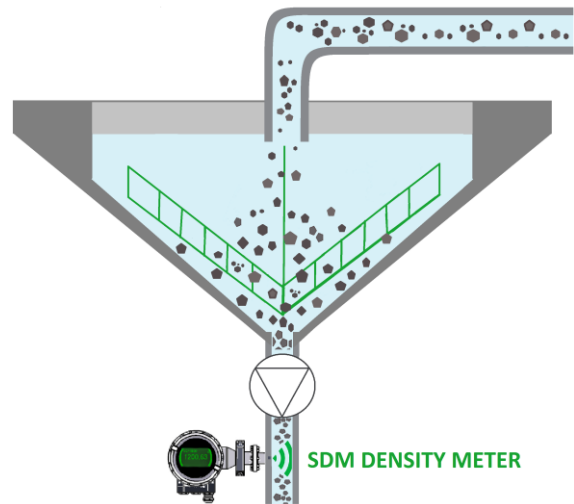

Density measurement in the slurry of a thickener underflow

## INSTALLATION METHODS

Rhosonics offers different installation methods to fit every customer's need. The most important installation methods are discussed.

- UFTP Spool (with/without liner)
- Weldolet
- UWC Wafer

**Spool** (with or without liner)

A spool is a pipe piece which can be mounted between two flanges. The spool piece can be made of HDPE, steel A106/A105 or other steel grades. Also, this installation method is available with PU liner, Ceramic liner and other liners on request. The choice of materials can be different for each customer application.

**Weldolet**

The Weldolet is a metal adapter which can be used for flush-mounted installation in new or existing steel pipes. This Weldolet piece is welded on the outside of the pipe at the location where a hole is drilled. This installation method is mostly used in dredging applications.

**UWC Wafer** (Ultrasonic Wafer Cell)

The UWC is a synthetic 60 mm thick ring made of UHPE (Ultra High Density Poly Ethylene). It can be clamped between two flanges in almost every pipe system. The UWC Wafer is a perfect solution for all thickener underflow applications.

**HOW DOES IT WORK?**

The ultrasonic density measurement is based on the measurement of the acoustic impedance using the Physical law established by Sir Rayleigh.

$$Z = C \times \rho$$

Z = acoustic impedance  
C = speed of sound  
 $\rho$  = density

The acoustic impedance is the reflection of the ultrasonic signal on the interface between the sensor and the slurry medium. The speed of sound is based on the sound velocity of water which is programmed in the analyser.

Ultrasonic measurement principle

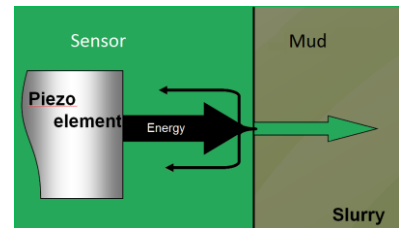

**SDM MODELS**

	 Example: UFTP A106 steel with PU liner				
SDM MODEL	SDM-1 & SDM-4	SDM-2 & SDM-3		SDM-4 & SDM-5	
Installation method	FDSC or UFTP Spool	Weldolet		UWC Wafer	
Suitable for nominal pipe OD	1" ... 16"	All	All	3" ...30" *	30" ...60" *
Sensor length (in mm)	16 or 146	34	52	146	200
Suitable for pipe WT (in mm)	N/A	2...17	17...40	N/A	N/A

\* Depending on the standard, determined by Rhosonics

## PERFORMANCE SPECIFICATIONS

Method:	Ultrasonic Spectral Power / Acoustic impedance
Density Range:	700 ... 3.000 g/l
Resolution:	0.2 g/l
Readings:	S.G., Density g/l
Accuracy:	Up to 0.005 S.G ... +/- 0.5%
Decay time:	1 to 99 s (adjustable)
Display:	Monochrome display with RGB backlight, visible through glass cover.
Operation:	Push-buttons, HART, Computer <i>Optional: RCU Remote Control Unit</i>

## GENERAL SPECIFICATIONS

<b>Process conditions</b>	
Pressure:	1 ... 16 bar
Temperature:	0 °C ... 110 °C (32 °F ... 230 °F)
Wetted materials:	Ceramics and Duplex Stainless steel 1.4462
<b>Electrical specifications</b>	
Power supply:	18 ... 32 VDC, 8 Watt <i>Optional: Power supply/converter for 90 ... 240 VAC</i>
Output:	4 ... 20 mA / HART
Communication:	2-way through HART protocol <i>Optional: RCU unit as converter to Modbus RTU or Profibus DP</i>
Data logging & fault reporting:	Internal memory, via USB memory stick
Cable entries:	3X M16X1.5, cable OD $\varnothing$ 3-10 mm
<b>Ambient conditions</b>	
Ambient temperature:	-20 °C ... +65 °C (-4 °F ... 149 °F)
Humidity:	< 95% at 40 °C (noncondensing)
Protection:	IP68, NEMA 6P
Vibration:	Resistant to moderate / high vibration of pumps
<b>Dimensions and weights</b>	
Weight:	Approx. 6.4 – 6.8 kg
Housing materials:	Coated stainless steel
Housing dimensions:	218 – 402 mm * (L) x 208 (W) x 170 mm (H) * Various lengths, depending on probe type
Process connection:	Spool (sensor length: 16 or 146 mm) Weldolet (sensor length: 34 or 52 mm) Wafer (sensor length: 146 or 200 mm)
Standards:	DIN/ANSI/JIS (others on request)
Nominal pipe size:	Up to 60"

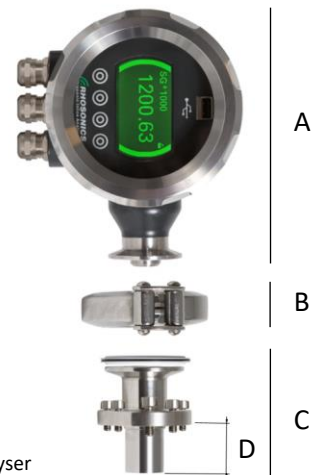
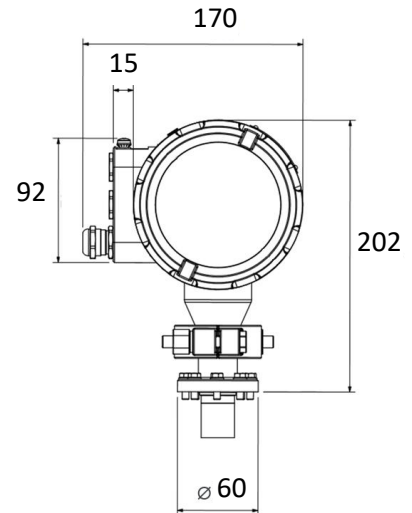
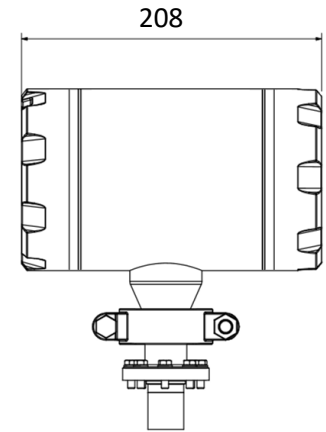

A: Analyser  
B: Tri-clamp  
C: Sensor  
D: Various lengths 34/52/146/200 mm



## About us



## MEASURING BEYOND LIMITS

Rhosonics is based in the Netherlands in Putten. We design, produce and supply state-of-the-art measuring instruments for virtually any industry. The company cooperates with partners worldwide to offer the best technology solutions. We use craftsmanship, capability and creativity to create measurements beyond limits.



We proudly meet the requirements for the ISO9001 standard since 2010.

## CONTACT US

### Rhosonics

Hoge Eng West 30, 3882 TR Putten, NL  
+31 341 – 37 00 73  
info@rhosonics.com  
www.rhosonics.com

### Distributor

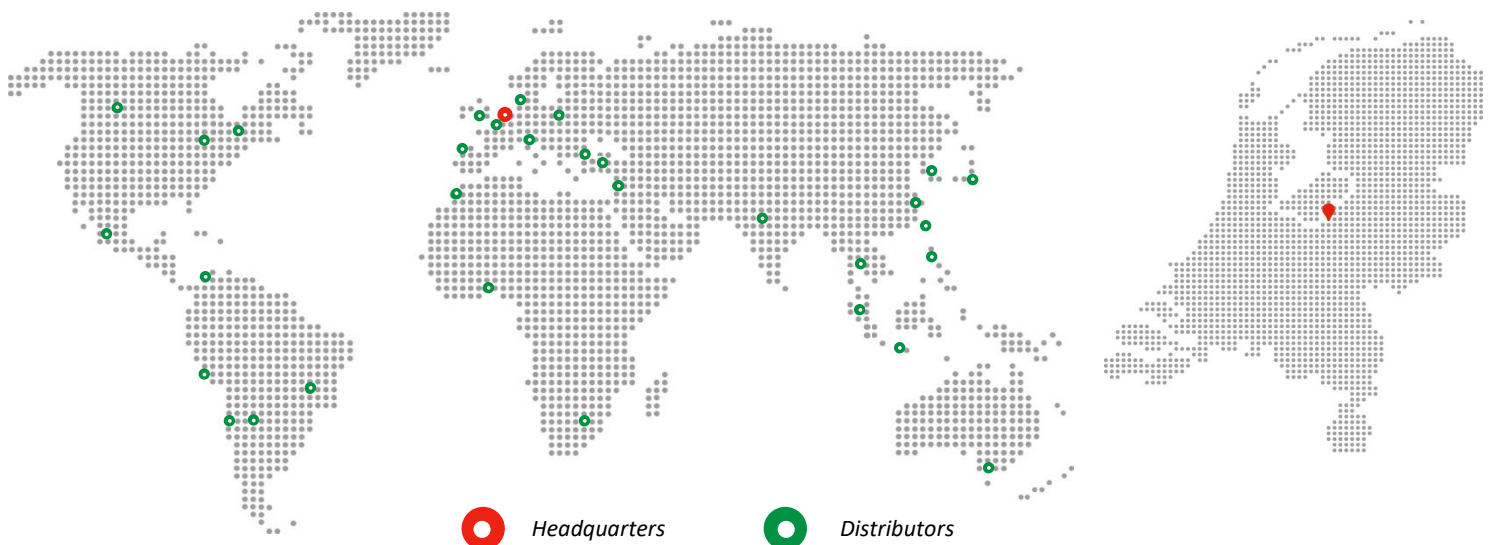

We work with a global network of specialized distributors. Please check our website for distributors in your specific region.